

## HDMI over Cat6 Extender Kits, Repeater and Receivers, 4K/60 Hz



Purchased product  
may differ from image.

Models:

B127A-1A1-BHBH  
B127A-1A1-BHPH  
B127A-2A1-BHBH  
B127A-111-BHTH  
B127A-111-BDTH  
B127A-1A0-BH  
B127A-2A0-BH  
B127A-1P0-PH  
B127A-110-BH  
B127A-010-H

Este manual está disponible en español en la página de Eaton:  
[Tripplite.Eaton.com/support](http://Tripplite.Eaton.com/support)

Ce manuel est disponible en français sur le site Web de Eaton :  
[Tripplite.Eaton.com/support](http://Tripplite.Eaton.com/support)

Dieses Handbuch ist in deutscher Sprache auf der Eaton-Website verfügbar:  
[Tripplite.Eaton.com/support](http://Tripplite.Eaton.com/support)

Questo manuale è disponibile in italiano sul sito web di Eaton:  
[Tripplite.Eaton.com/support](http://Tripplite.Eaton.com/support)

# EAT•N

Powering Business Worldwide

## Package Contents

	<b>B127A-1A1-BHBH</b>	<b>B127A-2A1-BHBH</b>	<b>B127A-1A1-BHPH</b>	<b>B127A-111-BHTH</b>	<b>B127A-111-BDTH</b>	<b>B127A-110-BH</b>	<b>B127A-1A0-BH</b>	<b>B127A-2A0-BH</b>	<b>B127A-1P0-PH</b>	<b>B127A-010-H</b>
Local and Remote Units (LR), Remote Unit (R), Repeater Unit (RT)	LR	LR	LR	LR	LR	R	R	R	R	RT
External Power Supplies (0 or 1)	1	1	1	1	1	1	0	0	0	0
Mounting Hardware	Y	Y	Y	Y	Y	Y	Y	Y	Y	N

## Product Features

### **B127A-1A1-BHBH**

- HDMI over Cat6 Power over Cable (PoC) Extender Kit
- Extends a 4K x 2K (3840 x 2160) @ 60 Hz signal, as specified in HDMI 2.0, up to 230 ft. (70 m) from the source
- Built-in local HDMI port supports 4K @ 60 Hz signal
- Remote receiver unit features built-in equalization (EQ) control and auto EDID image adjustment
- Supports up to 7.1-channel surround sound audio
- Receiver features built-in Toslink port for audio extraction function

## Product Features

- Real-time video compression and decompression technology
- Receiver features built-in Toslink port for audio extraction function
- Compatible with HDCP 2.2, High Dynamic Range (HDR) and 36-bit color depth
- Plug and play—no software or drivers required
- Support bi-directional IR and USB 1.1 function by dip switch selection
- Includes mounting hardware that enables both the local transmitter and remote receiver units to be wall-mounted, rack-mounted or pole-mounted
- Power over Cable (PoC) function allows external power supply to be plugged in at either transmitter or receiver side and provide power to both units

### **B127A-2A1-BHBH**

- HDMI over Cat6 Power over Cable (PoC) Dual Output Extender Kit
- Extends a 4K x 2K (3840 x 2160) @ 60 Hz signal, as specified in HDMI 2.0, up to 230 ft. (70m) from the source to two displays
- Built-in local HDMI port supports 4K x 2K signal
- Remote receiver unit features built-in equalization (EQ) control and auto EDID image adjustment
- Supports up to 7.1-channel surround sound audio
- Real-time video compression and decompression technology

## Product Features

- Receiver features built-in Toslink port for audio extraction function
- Compatible with HDCP 2.2, High Dynamic Range (HDR) and 36-bit color depth
- Plug and play—no software or drivers required
- Includes mounting hardware that enables both the local transmitter and remote receiver units to be wall-mounted, rack-mounted or pole-mounted
- Power over Cable (PoC) function allows external power supply to be plugged in at either transmitter or receiver side and provide power to both units

### **B127A-1A1-BHPH**

- HDMI over Cat6 Power over Cable (PoC) Extender Kit with Pigtail Receiver
- Extends a 4K x 2K (3840 x 2160) @ 60 Hz signal, as specified in HDMI 2.0, up to 230 ft. (70 m) from the source
- Built-in local HDMI port supports 4K @ 60 Hz signal
- Remote receiver unit features built-in equalization (EQ) control and auto EDID image adjustment with 1 ft. HDMI male cable
- Supports up to 7.1-channel surround sound audio
- Compatible with HDCP 2.2, High Dynamic Range (HDR) and 36-bit color depth
- Plug and play—no software or drivers required
- Includes mounting hardware that enables the local transmitter to be wall-mounted, rack-mounted or pole-mounted

## Product Features

- Power over Cable (PoC) function allows external power supply to be plugged into transmitter and provide power to both units

### **B127A-111-BHTH**

- HDMI over Cat6 Power over Cable (PoC) daisy-chainable Extender Kit
- Remote transceiver unit features built-in equalization (EQ) control, auto EDID image adjustment and RJ45 expanding port to be able to connect to next B127A-110-BH
- Transceiver features built-in Toslink port for audio extraction function
- Real-time video compression and decompression technology
- Extends and expands a 4K x 2K (3840 x 2160) @ 60 Hz signal, as specified in HDMI 2.0, in an over Cat6 installation, allowing multiple monitors to be located at different points in a chain by adding up to four B127A-110-BH units
- Extends a 4K (3840 x 2160) @ 60 Hz signal up to an additional 230 ft. or a 1080p @ 60 Hz signal up to an additional 230 ft. from each remote/repeater unit to the next unit in the chain (in a full four-level daisy-chain installation), a 4K (3840 x 216) @ 60 Hz signal up to 920 ft. or a 1080p @ 60 Hz signal up to 920 ft. from the source to the last remote unit in the chain
- Increase the maximum transmission distance to 1,090 ft. by adding a B127A-010-H signal booster to the first link of a daisy-chain installation

**Note:** *The signal booster will only work when used in the first link of the daisy-chain installation.*

## Product Features

- Supports up to 7.1-channel surround sound audio
- Transceiver features built-in Toslink port for audio extraction function
- Compatible with HDCP 2.2, High Dynamic Range (HDR) and 36-bit color depth
- Plug and play—no software or drivers required
- Includes mounting hardware that enables the transmitter and transceiver units to be wall-mounted, rack-mounted or pole-mounted
- Power over Cable (PoC) function allows external power supply to be plugged into either transmitter or receiver side and provide power to connected units

### **B127A-110-BH**

- HDMI over Cat6 Power over Cable (PoC) transceiver unit
- Works with the B127A-111-BHTH to extend a 4K x 2K (3840 x 2160) @ 60 Hz signal, as specified in HDMI 2.0, up to 230 ft. (70 m)
- This transceiver unit features built-in equalization (EQ) control and auto EDID image adjustment and one RJ-45 expanding port to be able to connect to next B127A-110-BH
- Transceiver features built-in Toslink port for audio extraction function
- Compatible with HDCP 2.2, High Dynamic Range (HDR) and 36-bit color depth
- Plug and play—no software or drivers required
- Bi-directional IR function

## Product Features

- Real-time video compression and decompression technology
- Add a B127A-010-H signal booster for increased maximum transmission distance. See B127A-111-BHTH for details.

### **B127A-111-BDTH**

- DisplayPort to HDMI over Cat6 with Power over Cable (PoC) daisy-chainable Extender Kit
- Extends audio/video signal from a DisplayPort source to an HDMI display
- Remote transceiver unit features built-in equalization (EQ) control, auto EDID image adjustment and RJ45 expanding port to be able to connect to next B127A-110-BH
- Transceiver features built-in Toslink port for audio extraction function
- Real-time video compression and decompression technology
- Extends and expands a 4K x 2K (3840 x 2160) @ 60 Hz signal, as specified in HDMI 2.0, in an over Cat6 installation, allowing multiple monitors to be located at different points in a chain by adding up to four B127A-110-BH units
- Extends a 4K (3840 x 2160) @ 60 Hz signal up to an additional 230 ft. or a 1080p @ 60 Hz signal up to an additional 230 ft. from each remote/repeater unit to the next unit in the chain (in a full four-level daisy-chain installation), a 4K (3840 x 216) @ 60 Hz signal up to 920 ft. or a 1080p @ 60 Hz signal up to 920 ft. from the source to the last remote unit in the chain

## Product Features

- Increase the maximum transmission distance to 1,090 ft. by adding a B127A-010-H signal booster to the first link of a daisy-chain installation

**Note:** *The signal booster will only work when used in the first link of the daisy-chain installation.*

- Supports up to 7.1-channel surround sound audio
- Transceiver features built-in Toslink port for audio extraction function
- Compatible with DisplayPort 1.2a, HDCP 2.2, High Dynamic Range (HDR) and 36-bit color depth
- Plug and play—no software or drivers required
- Includes mounting hardware that enables the transmitter and transceiver units to be wall-mounted, rack-mounted or pole-mounted
- Power over Cable (PoC) function allows external power supply to be plugged into either transmitter or receiver side and provide power to connected units

### **B127A-1A0-BH**

- HDMI over Cat6 Power over Cable (PoC)-Compatible Receiver
- Connects to a B127A-Series transmitter, switch or splitter unit to extend a 4K x 2K (3840 x 2160) @ 60 Hz signal, as specified in HDMI 2.0, up to 230 ft. (70m) from the source
- Remote receiver unit features built-in equalization (EQ) control and auto EDID image adjustment
- Real-time video compression and decompression technology



## Product Features

- Features built-in Toslink port for audio extraction function
- Supports up to 7.1-channel surround sound audio
- Compatible with HDCP 2.2, High Dynamic Range (HDR) and 36-bit color depth
- Plug and play—no software or drivers required
- Includes mounting hardware that enables the local transmitter to be wall-mounted, rack-mounted or pole-mounted
- Power over Cable (PoC) function allows receiver unit to be powered by a connected transmitter, switch or splitter unit

### **B127A-2A0-BH**

- HDMI over Cat6 Power over Cable (PoC)-Compatible Dual Output Receiver
- Connects to a B127A-Series transmitter, switch or splitter unit to extend a 4K x 2K (3840 x 2160) @ 60 Hz signal, as specified in HDMI 2.0, to two displays up to 230 ft. (70m) from the source
- Remote receiver unit features built-in equalization (EQ) control and auto EDID image adjustment
- Real-time video compression and decompression technology
- Features built-in Toslink port for audio extraction function
- Supports up to 7.1-channel surround sound audio
- Compatible with HDCP 2.2, High Dynamic Range (HDR) and 36-bit color depth
- Plug and play—no software or drivers required

## Product Features

- Includes mounting hardware that enables the local transmitter to be wall-mounted, rack-mounted or pole-mounted
- Power over Cable (PoC) function allows receiver unit to be powered by a connected transmitter, switch or splitter unit

### **B127A-1P0-PH**

- HDMI over Cat6 Power over Cable (PoC)-Compatible Pigtail Receiver
- Connects to a B127A-Series transmitter, switch or splitter unit to extend a 4K x 2K (3840 x 2160) @ 60 Hz signal, as specified in HDMI 2.0, up to 230 ft. (70m) from the source
- Remote receiver unit features built-in equalization (EQ) control and auto EDID image adjustment
- Real-time video compression and decompression technology
- Supports up to 7.1-channel surround sound audio
- Compatible with HDCP 2.2, High Dynamic Range (HDR) and 36-bit color depth
- Plug and play—no software or drivers required
- Power over Cable (PoC) function allows receiver unit to be powered by a connected transmitter, switch or splitter unit

### **B127A-010-H**

- Over Cat6 signal repeater for B127A extenders
- Repeater unit extends the transmission of a 4K x 2K (3840 x 2160) @ 60 Hz signal, as specified in HDMI 2.0, up to a total of 400 ft. (120 m)

## Product Features

- Power over Cable (PoC) technology means no external power is required to power the unit
- HDCP 2.2- and HDR-compliant
- Supports up to 7.1-channel surround sound audio
- Compatible with all B127A-Series products, including HDMI, DisplayPort and USB-C models
- Plug and play—no software or drivers required
- Increase the maximum transmission distance to 1,090 ft. by adding a B127A-010-H signal booster to the first link of a B127A-111-BHTH and B127A-110-BH daisy-chain installation

**Note:** *The signal booster will only work when used in the first link of the daisy-chain installation.*

## Optional Accessories:

- N202-Series Cat6 24 AWG Solid Wire Patch Cables
- P569-XXX-CERT or P568-XXX-2A Series High-Speed HDMI 2.0 Cables

## Disclaimer

Before installation, please check the following settings of your source(s) and TV/monitor(s):

1. Set display to 60 Hz. Double-check factory settings, as default can be set to a lower frequency (Hz) than advertised.
2. Ensure the input setting of your monitor is set at HDMI 2.0. Some displays may have default setting at HDMI 1.4.
3. Verify your monitor has the HDR feature enabled. Some displays may have this feature disabled as a factory setting.
4. Check if the Ultra HD (UHD) Deep Color setting is enabled on your TV/monitor. Confirm with your TV/monitor manufacturer which HDMI ports support UHD Deep Color.

**Note:** Check USB/IR DIP switch, as the default setting is set to IR. This only applies to the B127A-1A1-BHBH.

**Note:** To connect a local monitor to your installation, the UHD Deep Color setting may need to be disabled on your local TV/monitor (depending make/mode) to achieve 4K @ 60 Hz resolution.

## Mounting Instructions (select models only)

The B127A-1A1-BHBH, B127A-2A1-BHBH, B127A-1A1-BHPH, B127A-111-BHTH, B127A-111-BDTH, B127A-1A0-BH, B127A-2A0-BH and B127A-110-BH include mounting hardware that allows for a variety of mounting methods.

The following images illustrate how the included mounting brackets can be attached for different installations.

### Notes:

- *The model shown in the below images is for illustrative purposes only. Your product may vary by model number, size or port orientation. The mounting options for all over IP units are the same.*
- *Only the transmitter unit in the B127A-1A1-BHPH can be mounted. The receiver is a pigtail-type unit that cannot be mounted.*

## Wall-Mount



## 19" Rack-Mount Pole-Mount

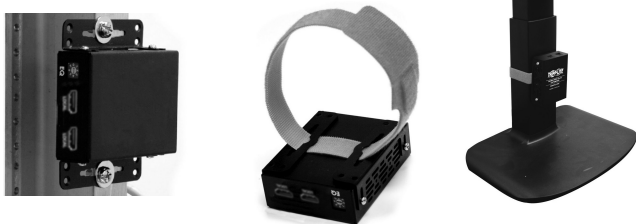

# Standard Extender Kit Installation

## Notes:

- Test to ensure the entire installation works properly before pulling cables through ceilings/walls.
- To achieve maximum distance and performance, use 24 AWG solid wire Cat6 cable. Using stranded wire Cat6 cable or cable with a gauge (AWG) size higher than 24 AWG will result in shorter extension distance. Higher-gauge cabling, such as 26 AWG, has a more limited transmission capability than lower-gauge cabling. All N202-Series Cat6 cables are made with 24 AWG solid wire cabling.
- The installation diagram shows a B127A-1A1-BHBH unit.
- External power is not required for remote receiver units due to Power over Cable (PoC) technology incorporated in the transmitter units.

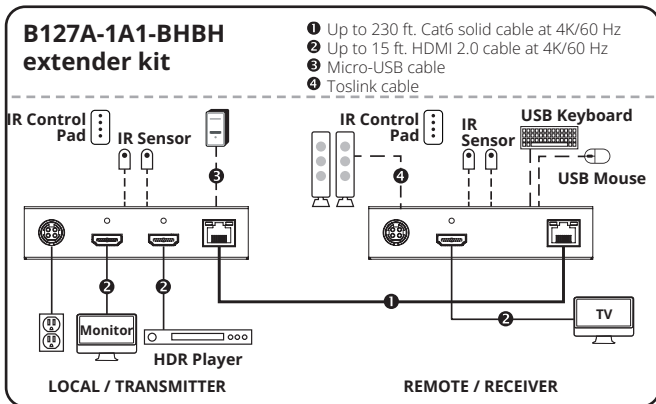

## Standard Extender Kit Installation

1. Make sure all equipment in the installation—such as TVs, Blu-ray™ players and the transmitter—is powered OFF.
2. Using an HDMI 2.0 cable (such as P569-XXX-CERT or P568-XXX-2A Series cables), connect the HDMI source to the INPUT port on the local transmitter unit.
3. **Optional for B127A-1A1-BHBH:** Using an HDMI 2.0 cable (such as P569-XXX-CERT or P568-XXX-2A Series cables), connect a local monitor to the LOCALOUT port on the B127A-1A1-BHBH local transmitter unit.
4. **Optional:** For extended range, connect a B127A-010-H signal repeater unit to the transmitter and receiver via Cat6 cabling. See B127A-010-H product features for more information.
5. Using Cat6 cable, connect the RJ45 port on the local transmitter unit to the RJ45 port on the remote receiver unit.
6. Using an HDMI 2.0 cable (such as P569-XXX-CERT or P568-XXX-2A Series cables), connect the remote receiver unit's HDMI port to a monitor.
7. Turn on the power to your connected TVs/monitors.

## Standard Extender Kit Installation

- 8.** Connect the external power supply to either the transmitter or receiver unit. Plug it into an available wall outlet or a surge protector, power distribution unit (PDU) or uninterruptible power supply (UPS). The POWER (green) LED on the local transmitter unit will illuminate to indicate the unit is receiving power from the external power supply. The POWER (green) LED on the remote receiver unit will illuminate to indicate the unit is receiving power from the local transmitter unit through PoC technology.
- 9.** Turn on the power to the HDMI source.
- 10.** The orange RJ45 LED will illuminate on both the local transmitter and remote receiver units to indicate a signal is being received from the source to display. The screen should now display on the connected monitor(s).



# Standard Extender Kit Installation

## Notes:

- Test to ensure the entire installation works properly before pulling cables through ceilings/walls.
- To achieve maximum distance and performance, use 24 AWG solid wire Cat6 cable. Using stranded wire Cat6 cable or cable with a gauge (AWG) size higher than 24 AWG will result in shorter extension distance. Higher-gauge cabling, such as 26 AWG, has a more limited transmission capability than lower-gauge cabling. N202-Series Cat6 cables are made with 24 AWG solid wire cabling.
- The installation diagram shows a B127A-2A1-BHBH unit.
- External power is not required for remote receiver units due to Power over Cable (PoC) technology incorporated in the transmitter units.

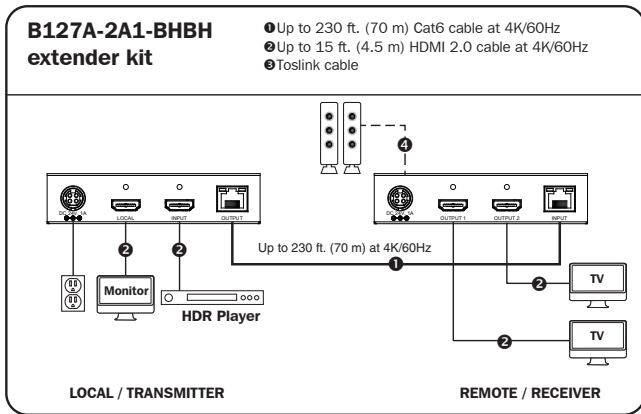

## Standard Extender Kit Installation

1. Make sure all equipment in the installation—such as TVs, Blu-ray players and the transmitter—is powered OFF.
2. Using an HDMI 2.0 cable (such as P569-XXX-CERT or P568-XXX-2A Series cables), connect the HDMI source to the INPUT port on the local transmitter unit.
3. **Optional for B127A-2A1-BHBH:** Using an HDMI 2.0 cable (such as P569-XXX-CERT or P568-XXX-2A Series cables), connect a local monitor to the LOCALOUT port on the B127A-2A1-BHBH local transmitter unit.
4. **Optional:** For extended range, connect a B127A-010-H signal repeater unit to the transmitter and receiver via Cat6 cabling. See B127A-010-H product features for more information.
5. Using Cat6 cable, connect the RJ45 port on the local transmitter unit to the RJ45 port on the remote receiver unit.
6. Using HDMI 2.0 cables (such as P569-XXX-CERT or P568-XXX-2A Series cables), connect the remote receiver unit's dual HDMI ports to the monitor(s).
7. Turn on the power to your connected TVs/monitors.

## Standard Extender Kit Installation

- 8.** Connect the external power supply to either the transmitter or receiver unit. Plug it into an available wall outlet or a surge protector, power distribution unit (PDU) or uninterruptible power supply (UPS). The POWER (green) LED on the local transmitter unit will illuminate to indicate the unit is receiving power from the external power supply. The POWER (green) LED on the remote receiver unit will illuminate to indicate the unit is receiving power from the local transmitter unit through PoC technology.
- 9.** Turn on the power to the HDMI source.
- 10.** The orange RJ45 LED will illuminate on both the local transmitter and remote receiver units to indicate a signal is being received from the source to display. The screen should now display on the connected monitor(s).

# Standard Extender Kit Installation

## Notes:

- Test to ensure the entire installation works properly before pulling cables through ceilings/walls.
- To achieve maximum distance and performance, use 24 AWG solid wire Cat6 cable. Using stranded wire Cat6 cable or cable with a gauge (AWG) size higher than 24 AWG will result in shorter extension distance. Higher-gauge cabling, such as 26 AWG, has a more limited transmission capability than lower-gauge cabling. N202-Series Cat6 cables are made with 24 AWG solid wire cabling.
- The installation diagram shows a B127A-1A1-BHPH unit.
- External power is not required for remote receiver units due to Power over Cable (PoC) technology incorporated in the transmitter units.

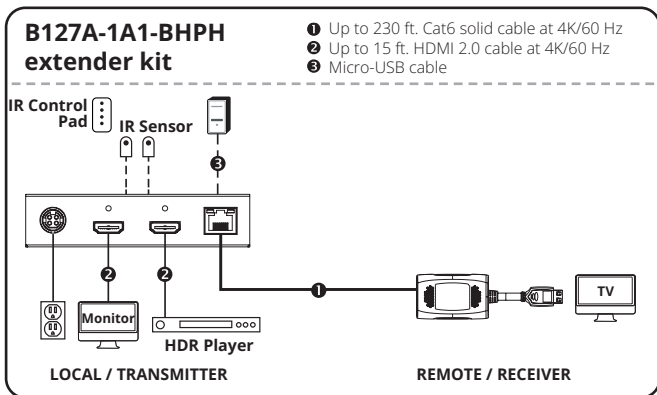

## Standard Extender Kit Installation

1. Make sure all equipment in the installation—such as TVs, Blu-ray players and the transmitter—is powered OFF.
2. Using an HDMI 2.0 cable (such as P569-XXX-CERT or P568-XXX-2A Series cables), connect the HDMI source to the INPUT port on the local transmitter unit.
3. **Optional for B127A-1A1-BHPH:** Using an HDMI 2.0 cable (such as P569-XXX-CERT or P568-XXX-2A Series cables), connect a local monitor to the LOCALOUT port on the B127A-1A1-BHPH local transmitter unit.
4. **Optional:** For extended range, connect a B127A-010-H signal repeater unit to the transmitter and receiver via Cat6 cabling. See B127A-010-H product features for more information.
5. Using Cat6 cable, connect the RJ45 port on the local transmitter unit to the RJ45 port on the remote receiver unit.
6. Using an HDMI 2.0 cable (such as P569-XXX-CERT or P568-XXX-2A Series cables), connect the remote receiver unit's HDMI port to a monitor.
7. Turn on the power to your connected TVs/monitors.
8. Connect the external power supply to either the transmitter or receiver unit. Plug it into an available wall outlet or a surge protector, power distribution unit (PDU) or uninterruptible power supply (UPS). The POWER (green) LED on the local transmitter unit will illuminate to indicate the unit is receiving power from the external power supply.
9. Turn on the power to the HDMI source.

## Standard Extender Kit Installation

- 10.** The orange RJ45 LED will illuminate on both the local transmitter and remote receiver units to indicate a signal is being received from the source to display. The screen should now display on the connected monitor(s).

# Standard Extender Kit Installation

## Notes:

- Test to ensure the entire installation works properly before pulling cables through ceilings/walls.
- To achieve maximum distance and performance, use 24 AWG solid wire Cat6 cable. Using stranded wire Cat6 cable or cable with a gauge (AWG) size higher than 24 AWG will result in shorter extension distance. Higher-gauge cabling, such as 26 AWG, has a more limited transmission capability than lower-gauge cabling. N202-Series Cat6 cables are made with 24 AWG solid wire cabling.
- The installation diagram shows a B127A-002-BH splitter unit (sold separately) with B127A-1A0-PH and B127A-1A0-BH receiver units. The B127A-1A0-BH, B127A-2A0-BH and B127A-1P0-PH receiver units can be used with a variety of B127A-Series transmitter and splitter units. See [TrippLite.Eaton.com](http://TrippLite.Eaton.com) for details.
- External power is not required for remote receiver units due to Power over Cable (PoC) technology incorporated in the transmitter units.

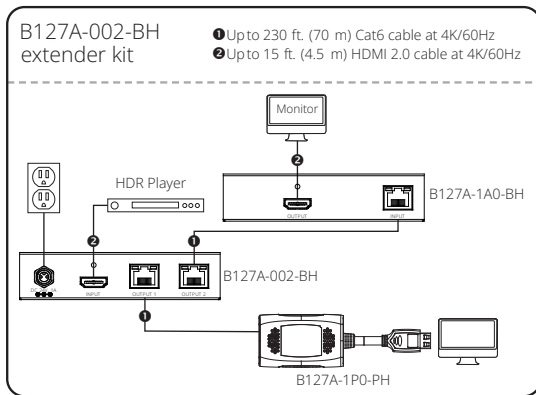

## Standard Extender Kit Installation

1. Make sure all equipment in the installation—such as TVs, Blu-ray players and the transmitter—is powered OFF.
2. Using an HDMI 2.0 cable (such as P569-XXX-CERT or P568-XXX-2A Series cables), connect the HDMI source to the INPUT port on the local transmitter unit.
3. **Optional for B127A-Series Transmitter/Splitter Units:** Using an HDMI 2.0 cable (such as P569-XXX-CERT or P568-XXX-2A Series cables), connect a local monitor to the LOCALOUT port on the local transmitter unit.
4. **Optional:** For extended range, connect a B127A-010-H signal repeater unit to the transmitter or splitter and receiver via Cat6 cabling. See B127A-010-H product features for more information.
5. Using Cat6 cable, connect the RJ45 port on the local transmitter, splitter or switch unit to the RJ45 port on the remote receiver unit.
6. Connect the remote receiver unit's HDMI cable to a monitor/TV (B127A-1P0-PH only), or using HDMI 2.0 cable (such as P569-XXX-CERT or P568-XXX-2A Series cables) connect the receiver unit's HDMI output port to a monitor/TV.
7. Turn on the power to your connected TVs/monitors.



## Standard Extender Kit Installation

- 8.** Connect the external power supply to the transmitter unit. Plug it into an available wall outlet or a surge protector, power distribution unit or uninterruptible power supply (UPS). The POWER (green) LED on the local transmitter/splitter unit will illuminate to indicate the unit is receiving power from the external power supply. The POWER (green) LED on the remote receiver unit will illuminate to indicate the unit is receiving power from the local transmitter unit through PoC technology (B127A-1A0-BH and B127A-2A0-BH only).
- 9.** Turn on the power to the HDMI source.
- 10.** The orange RJ45 LED will illuminate on both local transmitter and remote receiver units to indicate a signal is being received from source to display. The screen should now display on the connected monitor(s).

## Standard Extender Kit Installation

### Notes:

- *Test to ensure the entire installation works properly before pulling cables through ceilings/walls.*
- *To achieve maximum distance and performance, use 24 AWG solid wire Cat6 cable. Using stranded wire Cat6 cable, or cable with a gauge (AWG) size higher than 24 AWG, will result in shorter extension distance. Higher-gauge cabling, such as 26 AWG, has a more limited transmission capability than lower-gauge cabling. N202-Series Cat6 cables are made with 24 AWG solid wire cabling.*
- *The installation diagram shows a B127A-111-BHTH transmitter and transceiver with an additional transceiver attached to demonstrate the kit's daisy-chain capabilities.*
- *External power is not required for remote receiver units due to Power over Cable (PoC) technology incorporated in the transmitter units.*

# Standard Extender Kit Installation

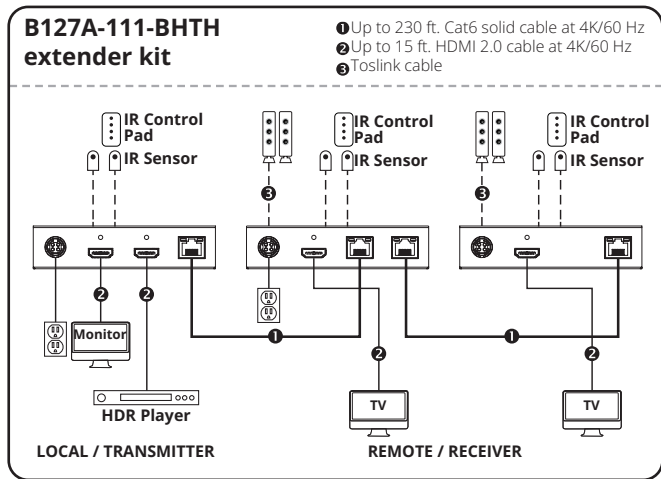

1. Make sure all equipment in the installation—such as TVs, Blu-ray players and the transmitter—is powered OFF.
2. Using an HDMI 2.0 cable (such as P569-XXX-CERT or P568-XXX-2A Series cables), connect the HDMI source to the INPUT port on the local transmitter unit.
3. **Optional for B127A-111-BHTH:** Using an HDMI 2.0 cable (such as P569-XXX-CERT or P568-XXX-2A Series cables), connect a local monitor to the LOCALOUT port on the B127A-111-BHTH local transmitter unit.

## Standard Extender Kit Installation

- 4. Optional:** To extend the transmission distance up to 400 ft. connect a B127A-010-H signal booster between the transmitter and receiver unit using Cat6 cable.

**Note:** *In a daisy-chain installation the B127A-010-H signal booster unit must be placed between the transmitter and first transceiver unit in the chain or else the signal booster will not function.*

- 5.** Using Cat6 cable, connect the RJ45 port on the local transmitter unit to the RJ45 port on the remote receiver unit.
- 6.** Using an HDMI 2.0 cable (such as P569-XXX-CERT or P568-XXX-2A Series cables), connect the remote receiver or transceiver unit's HDMI port to a monitor.
- 7.** Turn on the power to your connected TVs/monitors.
- 8.** Connect the external power supply to the transmitter. Plug it into an available wall outlet or a surge protector, power distribution or uninterruptible power supply (UPS). The POWER (green) LED on the local transmitter unit will illuminate to indicate the unit is receiving power from the external power supply. The POWER (green) LED on the remote receiver unit will illuminate to indicate the unit is receiving power from the local transmitter unit through PoC technology.
- 9.** Turn on the power to the HDMI source.
- 10.** The orange RJ45 LED will illuminate on both the local transmitter and remote receiver units to indicate a signal is being received from the source to display. The screen should now display on the connected monitor.

# Standard Extender Kit Installation

## Notes:

- Test to ensure the entire installation works properly before pulling cables through ceilings/walls.
- To achieve maximum distance and performance, use 24 AWG solid wire Cat6 cable. Using stranded wire Cat6 cable, or cable with a gauge (AWG) size higher than 24 AWG, will result in shorter extension distance. Higher-gauge cabling, such as 26 AWG, has a more limited transmission capability than lower-gauge cabling. N202-Series Cat6 cables are made with 24 AWG solid wire cabling.
- The installation diagram shows a B127A-111-BDTH transmitter and transceiver with an additional transceiver attached to demonstrate the kit's daisy-chain capabilities.
- External power is not required for remote receiver units due to Power over Cable (PoC) technology incorporated in the transmitter units.

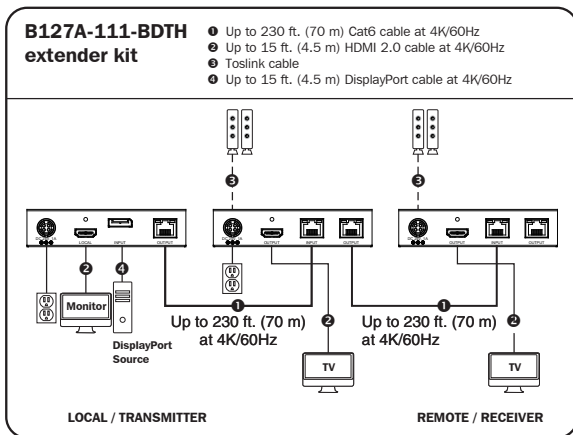

## Standard Extender Kit Installation

1. Make sure all equipment in the installation—such as TVs, Blu-ray players and the transmitter—is powered OFF.
2. Using a DisplayPort cable (such as P580-Series cables), connect the DisplayPort source to the INPUT port on the local transmitter unit.
3. **Optional for B127A-111-BDTH:** Using an HDMI 2.0 cable (such as P569-XXX-CERT or P568-XXX-2A Series cables), connect a local monitor to the LOCALOUT port on the B127A-111-BDTH local transmitter unit.
4. **Optional:** To extend the transmission distance up to 400 ft. connect a B127A-010-H signal booster between the transmitter and receiver unit using Cat6 cable.  
**Note:** *In a daisy-chain installation the B127A-010-H signal booster unit must be placed between the transmitter and first transceiver unit in the chain or else the signal booster will not function.*
5. Using Cat6 cable, connect the RJ45 port on the local transmitter unit to the RJ45 port on the remote receiver unit.
6. Using an HDMI 2.0 cable (such as P569-XXX-CERT or P568-XXX-2A Series cables), connect the remote transceiver unit's HDMI port to a monitor.
7. Turn on the power to your connected TVs/monitors.

## Standard Extender Kit Installation

8. Connect the external power supply to the transmitter. Plug it into an available wall outlet or a surge protector, power distribution or uninterruptible power supply (UPS). The POWER (green) LED on the local transmitter unit will illuminate to indicate the unit is receiving power from the external power supply. The POWER (green) LED on the remote receiver unit will illuminate to indicate the unit is receiving power from the local transmitter unit through PoC technology.
9. Turn on the power to the HDMI source.
10. The orange RJ45 LED will illuminate on both the local transmitter and remote receiver units to indicate a signal is being received from the source to display. The screen should now display on the connected monitor.

## Transceiver Daisy-Chain Installation (B127A-110-BH only)

### Notes:

- *Test to ensure the entire installation works properly before pulling cables through ceilings/walls.*
- *To achieve maximum distance and performance, use 24 AWG solid wire Cat5e/6 cable. Using stranded wire Cat5e/6 cable or cable with a gauge (AWG) size higher than 24 AWG will result in shorter extension distance. Higher-gauge cabling, such as 26 AWG, has a more limited transmission capability than lower-gauge cabling. N202-Series Cat6 cables are made with 24 AWG solid wire cabling.*
- *The installation diagram shows the B127A-111-BH and B127A-110-BH installation.*

# Transceiver Daisy-Chain Installation

(B127A-110-BH only)

## B127A-110-BH transceiver

- ❶ Up to 230 ft. Cat6 solid cable at 4K/60 Hz
- ❷ Up to 15 ft. HDMI 2.0 cable at 4K/60 Hz
- ❸ Toslink cable

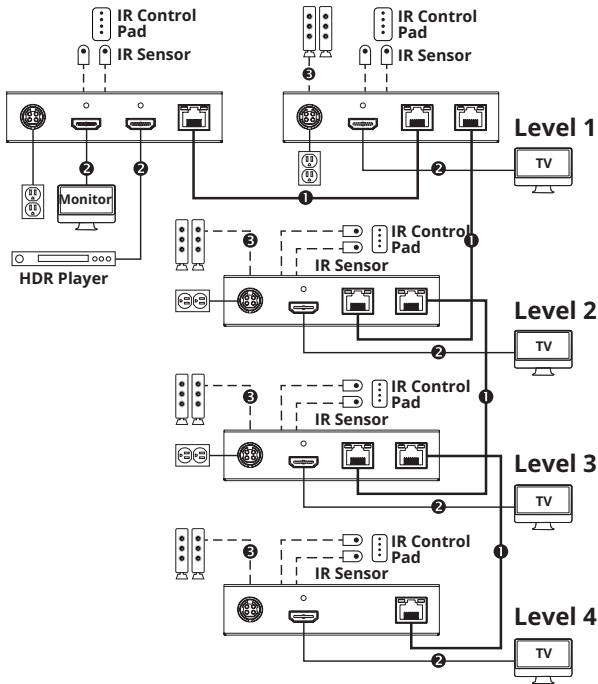



## **Transceiver Daisy-Chain Installation**

**(B127A-110-BH only)**

- 1.** Make sure all equipment in the installation—such as TVs, Blu-ray players and the transmitter—is powered OFF.
- 2.** Connect the HDMI source to the INPUT port on the B127A-111-BH using a P569-XXX-CERT or P568-XXX-2A Series HDMI Cable.
- 3.** Connect a local monitor to the LOCAL HDMI port using a P569-XXX-CERT or P568-XXX-2A Series HDMI Cable.
- 4.** Connect the external power supply to the local unit and plug it into a surge protector, power distribution unit (PDU) or uninterruptible power supply (UPS). The green RJ45 LEDs will illuminate to indicate power is being received from the external power supply.
- 5.** Using Cat5e/6 cable, connect one of the RJ45 output ports on the local unit to the RJ45 input port on the B127A-110-BH transceiver unit.
- 6.** Connect a monitor to the HDMI OUTPUT port on the transceiver unit using a P569-XXX-CERT or P568-XXX-2A Series HDMI Cable.
- 7.** The green power LED and the green RJ45 LEDs on the transceiver will illuminate to indicate the unit is receiving power. Up to four units can be daisy-chained (three transceivers and one receiver). To connect additional transceiver units, proceed to step 8. To finish your installation with a B127A-110-BH unit, proceed to step 12.

## **Transceiver Daisy-Chain Installation** **(B127A-110-BH only)**

- 8.** Using Cat5e/6 cable, connect the RJ45 OUTPUT port on the B127A-111-BH receiver unit to the RJ45 INPUT port on B127A-110-BH.
- 9.** Connect a monitor to the HDMI OUTPUT port on the B127A-110-BH that you just added using a P569-XXX-CERT or P568-XXX-2A Series HDMI Cable
- 10.** Connect the external power supply to the B127A-110-BH and plug it into a surge protector, power distribution unit (PDU) or uninterruptible power supply (UPS). The green power LED and the green RJ45 LEDs will illuminate to indicate the unit is receiving power.
- 11.** To add a second B127A-110-BH, repeat steps 8 through 10. To finish your installation with a B127A-110-BH, proceed to step 12.
- 12.** Using Cat5e/6 cable, connect the RJ45 OUTPUT port on the last B127A-110-BH to the RJ45 INPUT port.
- 13.** Connect a monitor to the HDMI OUTPUT port on the B127A-110-BH using a P568-Series HDMI Cable.
- 14.** The green LED on the B127A-110-BH will illuminate to indicate the unit is receiving power from the previous transceiver. The orange LED will illuminate to indicate the unit is connected to a powered ON remote/repeater unit.
- 15.** Turn on the power to the HDMI source. The orange RJ45 LEDs on the local unit will illuminate to indicate a signal is being received from the source.

## Transceiver Daisy-Chain Installation

(B127A-110-BH only)

16. If necessary, use the Equalization control on the remote/repeater unit(s) and remote receiver unit to adjust the video image.
17. The maximum number of daisy-chain layers is four for a total distance of 920 ft., but the distance can be extended to 1,090 ft. when a B127A-010-H signal booster is used. See the B127A-010-H product features for details.

**Note:** *An improper Equalization setting can cause the monitor not to display a picture at all. Try each Equalization setting until an acceptable picture is displayed.*

## USB/IR Controls and Toslink Installation

Select extender kits provide the following functional controls:

- USB 1.1 – One Micro-USB input at transmitter, dual USB-A outputs at receiver
- Bi-Directional IR – Dual 3.5 mm jacks at both the transmitter and receiver
- Toslink output at receiver and transceiver

**(Optional)** Connect the included IR-OUT cable to the transmitter unit's IR-OUT port. Place the sensor on the IR-OUT cable in an unobstructed area within clear view of the device being controlled. Then connect the included IR-IN cable to the receiver unit's IR-IN port. The IR-IN cable will communicate the desired command via the transmitter's IR-OUT cable.

**Note:** *The IR-OUT cable receives the signal from the remote control and sends it to the device being controlled (e.g. Blu-ray player, etc.).*

**(Optional for B127A-1A1-BHBH only)** With a user-supplied USB Micro-B cable (such as U050-XXX Series USB cable), connect to the transmitter's Micro-B port. Then connect a keyboard and mouse to the available USB-A ports on the receiver unit. The USB and IR functions can be selected via DIP switch on the front of the transmitter unit.

**(Optional)** Using a Toslink cable (such as A102-XXM Series cables), connect the Toslink cable to a set of speakers, an audio receiver or other audio system equipped with Toslink digital outputs.

# Warranty and Product Registration

## 1-Year Limited Warranty

We warrant our products to be free from defects in materials and workmanship for a period of one (1) year from the date of initial purchase. Our obligation under this warranty is limited to repairing or replacing (at its sole option) any such defective products. Visit [Triplite.Eaton.com/support/product-returns](http://Triplite.Eaton.com/support/product-returns) before sending any equipment back for repair. This warranty does not apply to equipment which has been damaged by accident, negligence or misapplication or has been altered or modified in any way.

EXCEPT AS PROVIDED HEREIN, WE MAKE NO WARRANTIES, EXPRESS OR IMPLIED, INCLUDING WARRANTIES OF MERCHANTABILITY AND FITNESS FOR A PARTICULAR PURPOSE. Some states do not permit limitation or exclusion of implied warranties; therefore, the aforesaid limitation(s) or exclusion(s) may not apply to the purchaser.

EXCEPT AS PROVIDED ABOVE, IN NO EVENT WILL WE BE LIABLE FOR DIRECT, INDIRECT, SPECIAL, INCIDENTAL OR CONSEQUENTIAL DAMAGES ARISING OUT OF THE USE OF THIS PRODUCT, EVEN IF ADVISED OF THE POSSIBILITY OF SUCH DAMAGE. Specifically, we are not liable for any costs, such as lost profits or revenue, loss of equipment, loss of use of equipment, loss of software, loss of data, costs of substitutes, claims by third parties, or otherwise.

# Warranty and Product Registration

## WEEE Compliance Information for Customers and Recyclers (European Union)



Under the Waste Electrical and Electronic Equipment (WEEE) Directive and implementing regulations, when customers buy new electrical and electronic equipment from Eaton, they are entitled to:

- Send old equipment for recycling on a one-for-one, like-for-like basis (this varies depending on the country)
- Send the new equipment back for recycling when this ultimately becomes waste

### WARNING

Use of this equipment in life support applications where failure of this equipment can reasonably be expected to cause the failure of the life support equipment or to significantly affect its safety or effectiveness is not recommended.

Eaton has a policy of continuous improvement. Specifications are subject to change without notice. Photos and illustrations may differ slightly from actual products.





Eaton  
1000 Eaton Boulevard  
Cleveland, OH 44122  
United States  
Eaton.com

© 2023 Eaton  
All Rights Reserved  
Publication No. 23-09-159 /  
93-3CC9\_RevD  
September 2023



Eaton is a registered  
trademark.

All trademarks are property  
of their respective owners.